

Technical Description

E-82

Document information:		Translation Information	
Author/date:	S. Anlas / 21.10.05	Translated/date:	C.Carsted / 28.11.05
Department:	VI	Revised/date:	
Approved/date:	M.Kuhlmann / 04.11.05	Reference:	VI-Technical Description E-82-Rev002ger-eng
Revision	2/10.02.06		

Table of Contents

1 Brief Description..... 3

1.1 The ENERCON Concept 4

1.2 Rotor 6

1.3 Generator 6

1.4 Grid feed unit..... 7

1.5 Yaw control..... 9

1.6 Safety system 9

1.7 Control system10

2 Control System..... 11

2.1 Response to safety relevant sensor messages11

2.2 Starting the turbine.....11

2.3 Normal operation.....11

2.4 Idle mode12

2.5 Stopping the turbine.....12

2.6 Lack of wind.....13

2.7 Storm.....14

2.8 Yaw control.....14

3 Technical specifications: 16

ENERCON reserves the right to make any technical changes and improvements at any time without prior notice.

Document information:	Translation Information
Author/date: S. Anlas / 21.10.05	Translated/date: C.Carsted / 28.11.05
Department: VI	Revised/date:
Approved/date: M.Kuhlmann / 04.11.05	Reference: VI-Technical Description E-82-Rev002ger-eng
Revision 2/10.02.06	

The main objective of ENERCON design and engineering is to minimise loads. All turbine components are developed and constructed accordingly. The result is a turbine which is, amongst other things, convincing due to its low load level and long service life.

Output controlled by variable speed allows the E-82 to attain maximum operation efficiency without increasing operating loads in the full and partial load ranges and at the same time prevents undesirable output peaks thus guaranteeing excellent yield and a high quality of power fed into the grid.

1.1 The ENERCON Concept

ENERCON wind energy converters are characterised by the following features:

The inner ring of the ENERCON annular generator and the rotor of the E-82 form one unit. These two components are flanged directly to the hub so that they both rotate at the same low speed. Since there are no gears or other fast-rotating parts, energy loss between generator and rotor, noise emissions, the use of gear oil and mechanical wear are considerably reduced.

The output produced by the E-82 generator is fed via the ENERCON grid connection system into the power supply company's grid. The ENERCON grid connection system comprises a rectifier/inverter unit (converter). This system ensures that high-quality electricity is fed into the power supply company's network.

Using the converter, this grid connection concept permits the E-82's rotor to operate at variable speeds. The rotor rotates slowly at low wind speeds and quickly at high wind speeds. This optimises wind flow on the rotor blades. Moreover, variable speed also reduces loads caused by gusts.

Each of the three rotor blades is equipped with an electrical pitch system. The pitch system limits the rotor speed and the use of the wind's power thus allowing the output of the E-82 to be reduced to rated power, even within a short period. By pitching the rotor blades into the feathered position, the rotor stops without mechanical brakes exerting load on the drive train.

Document information:		Translation Information	
Author/date:	S. Anlas / 21.10.05	Translated/date:	C.Carsted / 28.11.05
Department:	VI	Revised/date:	
Approved/date:	M.Kuhlmann / 04.11.05	Reference:	VI-Technical Description E-82-Rev002ger-eng
Revision	2/10.02.06		

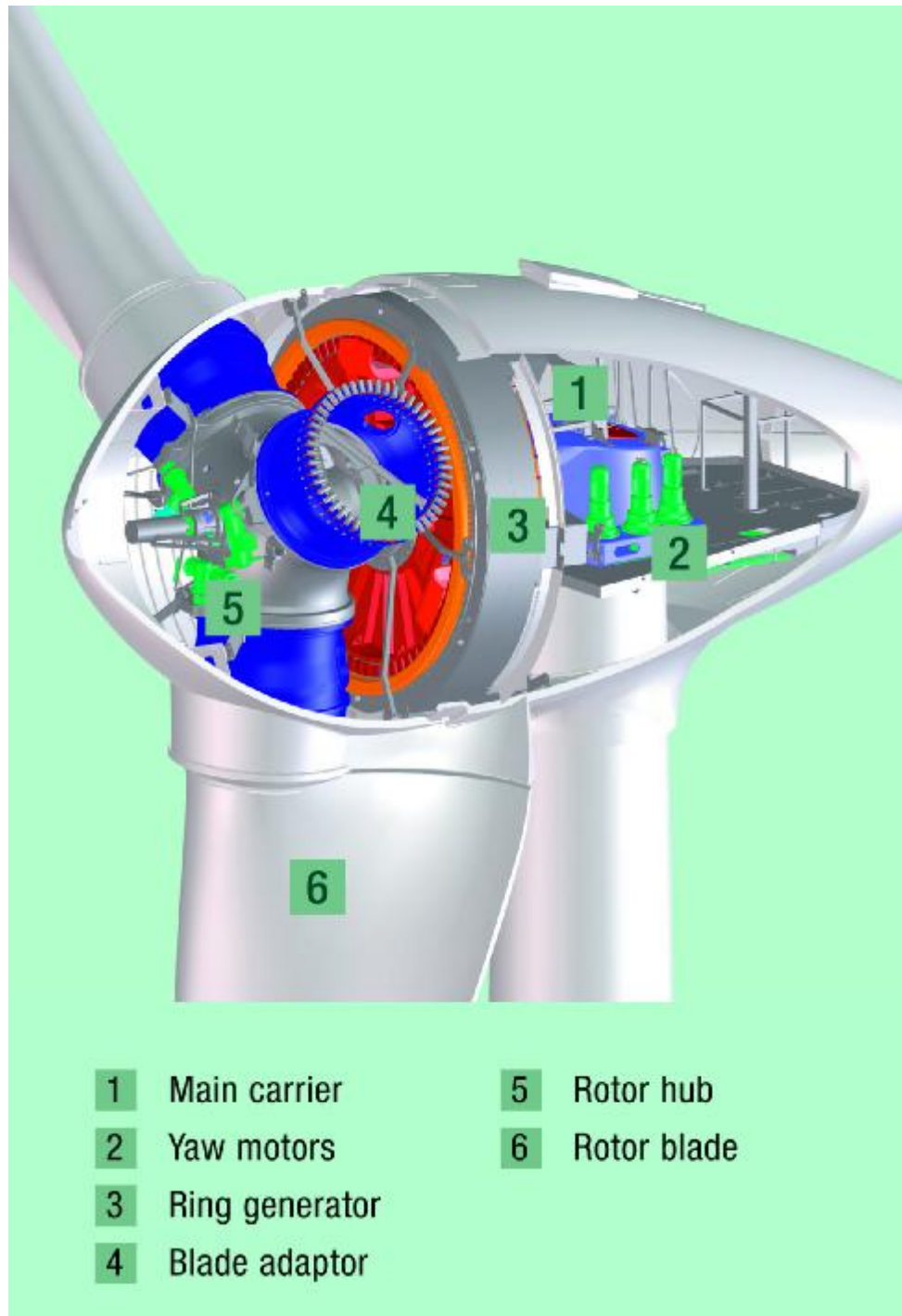

Figure 2: Illustration: Nacelle

Document information:		Translation Information	
Author/date:	S. Anlas / 21.10.05	Translated/date:	C.Carsted / 28.11.05
Department:	VI	Revised/date:	
Approved/date:	M.Kuhlmann / 04.11.05	Reference:	VI-Technical Description E-82-Rev002ger-eng
Revision	2/10.02.06		

1.2 Rotor

The E-82 rotor blades made of glass reinforced plastic (GRP) (epoxy resin) have a major influence on turbine output and its noise emission. Their shape and profile were developed according to the following criteria:

- high power coefficient
- long service life
- low noise emissions
- low loads and
- less material

One special feature to be pointed out is the new rotor blade profile which extends down to the nacelle. This innovative design eliminates the loss of the inner air flow experienced with conventional rotor blades. Together with the streamlined nacelle, the use of prevailing winds is considerably optimised.

The rotor blades of the E-82 were specially designed to operate with variable pitch control and variable speed. Due to this special profile, the blades are not sensitive to turbulence and dirt on the leading edge. On the outside, a top coat protects the rotor blades against environmental factors. The polyurethane-based material employed is highly resistant to abrasion, durable, and highly resistant to chemical factors and solar radiation.

Each of the three rotor blades is adjusted by independent microprocessor-controlled pitch systems. Angle encoders constantly monitor the set angle on each blade and ensure that the three blades are synchronised. This permits quick and accurate adjustment according to the prevailing wind conditions.

1.3 Generator

The air flow on the rotor blades drives the rotor which in turn is the direct drive for the E-82 annular generator. The multipole ENERCON generator is based on the direct drive synchronous machine principle.

Due to the low rotational speed and a large generator cross-section, temperature levels are comparatively low during operation and are only subject to minor fluctuations. Slight temperature fluctuations and comparatively few load changes during operation significantly decrease mechanical stress and the associated wear on generator material and insulation. Furthermore, variable speed and the connection to the electrical grid via converters contribute to reducing speed peaks.

Document information:	Translation Information
Author/date: S. Anlas / 21.10.05	Translated/date: C.Carsted / 28.11.05
Department: VI	Revised/date:
Approved/date: M.Kuhlmann / 04.11.05	Reference: VI-Technical Description E-82-Rev002ger-eng
Revision 2/10.02.06	

1.4 Grid feed unit

The annular generator is coupled with the grid via the ENERCON grid connection unit. The main components in this system are a rectifier, a DC link and modular inverters.

The grid feed unit, generator and pitch unit are all controlled to achieve maximum output and excellent grid compatibility.

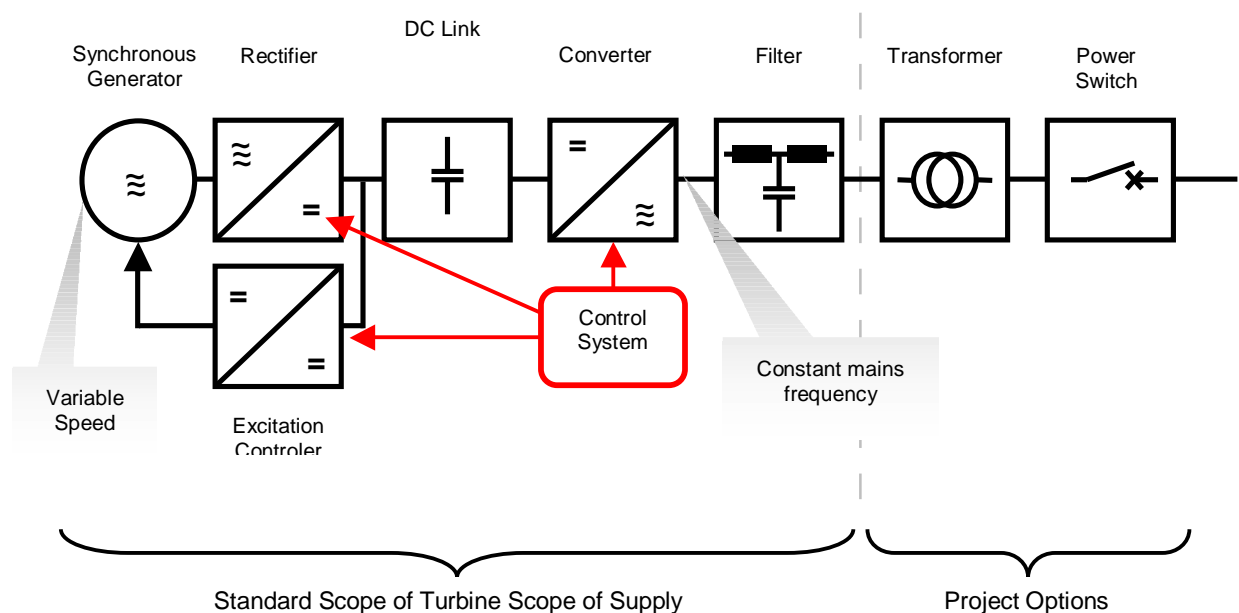

Flexible coupling between the annular generator and the grid guarantees ideal output transmission conditions while reducing undesirable reactions between the rotor and the grid in both directions. Sudden changes in wind speeds are controlled in order to maintain stable grid feed. Concurrently possible grid failures have very little effect on the mechanics. The power fed from the E-82 can be exactly regulated between 0 kW to 2000 kW

Depending on the technical configuration, eight or nine identical converter modules are aligned. They feed three-phase current from output on the low voltage side into the grid. Generally, a transformer directly in or near the turbine converts 400V to the desired high voltage.

Document information:	Translation Information
Author/date: S. Anlas / 21.10.05	Translated/date: C.Carsted / 28.11.05
Department: VI	Revised/date:
Approved/date: M.Kuhlmann / 04.11.05	Reference: VI-Technical Description E-82-Rev002ger-eng
Revision: 2/10.02.06	

With this converter technology, the wind energy turbine can be considered as a regulated source of power. As long as the voltage at the output terminals is within the permissible range, the converters feed symmetrical, sinusoidal current. The voltage at the output is affected by the feed but it is not actively controlled. If desired, a voltage regulator can be installed at the wind farm's point of common coupling.

Depending on the grid voltage phase angle and generator output, a target value for the current to be fed is generated. Three-phase current is then generated according to this target value with the power available in the DC link. This target value is compared to the actual current flow (actual value) every 100 μ s and corrected in the event of deviations. The current fed is sinusoidal and largely free of disruptive harmonic oscillations. A high frequency filter further reduces harmonics. No significant flicker emissions occur. Momentary current peaks are excluded with this converter technology.

The range of operation parallel to the grid is limited by the minimum and maximum grid voltage. Both these values (undervoltage and overvoltage) can be set as the limit value for the E-82.

Furthermore, ENERCON provides turbines as "transmission" versions on request. This means that the wind turbine can ride through voltage dips (grid failures) from one to several seconds instead of immediately disconnecting from the grid. As soon as voltage is re-established maximum possible active power is fed into the grid. During a grid failure, active power is fed into the grid depending on the remaining voltage, the maximum converter current and the actual wind conditions. In addition, the wind turbine can support the grid by feeding reactive current in the event of a grid failure. With this feature ENERCON wind turbines are able to provide wind farms with power plant properties often demanded and at the same time contribute to maintaining stable network operation.

The E-82 is preset to a power factor of $\cos\phi=1$. It does not require reactive power nor does it deliver reactive power to the grid within the entire power range from 0 to 2000 kW. Only active power is fed into the grid. Any equalization payments for reactive power demanded by some power supply network operators are not necessary.

However, if requested by the power supply network operators, it is also possible to run the turbine with an output factor of $\neq 1$. This enables the wind turbine to contribute to reactive power balance and to maintain the voltage in the grid. The maximum reactive power range varies depending on the turbine configuration. The active power being fed is not affected by reactive power being fed simultaneously.

The range of operation parallel to the grid is also determined by a lower and upper frequency limit value. The range between these frequency limits is much wider than in conventional energy production units thanks to ENERCON's flexible IGBT converter technology. ENERCON wind turbines can be used in grids with a rated frequency of 50 Hz or 60 Hz.

If these voltage or frequency limits cannot be maintained, the E-82 control unit switches off all grid contactors in the inverter. This allows the E-82 to immediately disconnect from the grid on all phases.

Document information:		Translation Information	
Author/date:	S. Anlas / 21.10.05	Translated/date:	C.Carsted / 28.11.05
Department:	VI	Revised/date:	
Approved/date:	M.Kuhlmann / 04.11.05	Reference:	VI-Technical Description E-82-Rev002ger-eng
Revision	2/10.02.06		

1.5 Yaw control

The yaw bearing is mounted directly at the top of the tower with an externally geared ring. The yaw bearing allows the nacelle to rotate, thus facilitating yaw control. Six adjustment drives (yaw gears) engage in the geared ring in order to adjust the nacelle to the wind direction. The yaw bearing also transmits the load of the nacelle to the tower. The main carrier is mounted directly on the yaw bearing.

1.6 Safety system

The safety system guarantees safe turbine operation in accordance with international standards and independent test institutes.

1.6.1 Brake System

Halting ENERCON turbine operation is done completely aerodynamically by pitching the rotor blades into the feathered position. The three independent pitch drives move the rotor blades into the feathered position within seconds (i.e. they are "driven out of the wind"). The speed of the turbine is diminished without applying additional load to the drive train. In order to reduce the rotor speed to a safe level, it would be sufficient to drive only one of the three rotor blades out of the wind.

The rotor is not locked in place even when the WEC is shut down. It idles freely at a very low speed. The rotor and drive train remain practically without load. While idling, fewer loads are placed on the bearings than when the rotor is locked.

The rotor is only completely locked in place for maintenance purposes or when the EMERGENCY STOP button is activated. In this case, an additional brake is employed. It does not engage until the rotor has already been partially braked with the pitch controls. The rotor lock is only used as a final safety mechanism for maintenance purposes.

In the event of an emergency (e.g. if the utility's mains fails), each rotor blade is safely brought into the feathered position via its own back-up pitch unit. The backup power units are monitored and automatically charged to guarantee availability. The backup pitch units, which are electromechanically linked, trigger simultaneous pitch control.

The pitch control system is equipped with parallel power supply in the case of emergencies (mains or backup power unit). Together with three fully independent pitch drives this safety concept more than fulfils the requirements for a fail safe braking system.

1.6.2 Lightning protection system

The ENERCON lightning conductor system in the E-82 efficiently diverts almost all possible lightning strikes with no damage caused to the turbine.

The leading and trailing edges of the rotor blade and the blade tip are equipped with aluminium profiles which are attached to an aluminium ring at the blade connection point. Strikes are safely absorbed by these profiles and the lightning current is conducted via a spark gap and cables into the ground surrounding the foundation.

Document information:	Translation Information
Author/date: S. Anlas / 21.10.05	Translated/date: C.Carsted / 28.11.05
Department: VI	Revised/date:
Approved/date: M.Kuhlmann / 04.11.05	Reference: VI-Technical Description E-82-Rev002ger-eng
Revision 2/10.02.06	

The rear of the nacelle casing is also fitted with a lightning conductor which diverts the current into the ground.

In the event of a lightning strike or an abnormal increase in voltage (overvoltage), the entire electrical and electronic equipment is protected by built-in energy-absorbing components. All main conductive turbine components are connected to the equipotential busbar with an adequate wire cross-section. Furthermore, overvoltage surge arresters are installed with low impedance grounding at the mains connection point.

The turbine electronics located in metal housing are electrically isolated. The remote monitoring system is protected by a special protection module for data interfaces.

1.6.3 Sensor System

A comprehensive monitoring system guarantees turbine safety. All safety related functions (e.g. rotor speed, temperature, loads, oscillations) are monitored by electronic media. If the electronics fail, a mechanical safety function takes over. If one of the sensors registers a serious fault, the turbine shuts down immediately.

1.7 Control system

The E-82 control system is based on a microprocessor system developed by ENERCON. Sensors query all turbine components and data such as wind direction and wind speed and adjust the operating mode of the E-82 accordingly.

When wind speeds suitable for turbine operation are measured over three consecutive minutes, the automatic startup process is initiated. Once the lower speed range limit is reached, power output is fed to the grid. Elevated making current does not occur at start-up since the grid connection is performed through the DC Link and the converter.

During operation at partial load, speed and rotor blade angle are continuously adjusted to the changing wind conditions. Power is controlled through generator excitation. If rated wind speed is exceeded, the blade angle is adjusted to maintain rated speed.

When the storm control system (optional) is deactivated, the turbine stops as soon as an average wind speed of 25 m/s in the 10-minute-mean or a peak value of 30 m/s is exceeded. The turbine restarts when the wind speed constantly remains below the shutdown wind speed. The rotor is permitted to idle freely at a very low speed even in the shutdown mode.

Yaw control begins even before the start-up speed has been reached. The wind vane constantly takes wind direction measurements. If the deviation between the direction of the rotor axis and the measured wind direction is too great, the yaw adjustment drives correct the nacelle position. The deviation angle and the time it takes for the nacelle position to be corrected vary depending on the wind speed.

Whether the turbine is stopped manually or via the turbine controls, the blade is pitched into the feathered position to reduce the actual contact surface of the wind flow on the blade. The turbine gradually slows down to idle mode.

Document information:		Translation Information	
Author/date:	S. Anlas / 21.10.05	Translated/date:	C.Carsted / 28.11.05
Department:	VI	Revised/date:	
Approved/date:	M.Kuhlmann / 04.11.05	Reference:	VI-Technical Description E-82-Rev002ger-eng
Revision	2/10.02.06		

2 CONTROL SYSTEM

2.1 Response to safety relevant sensor messages

Turbine response to messages received from individual sensors is explained in the following sections. If a safety relevant sensor responds, the turbine initiates an automatic shutdown. The nature of the shutdown and whether it is followed by a restart depends on the fault in question.

Turbine fault occurrences are displayed on the LCD. Minor faults can be reset by pressing the "Acknowledge fault" button once their cause has been established. Afterwards, the turbine automatically starts up again. Some faults may only be rectified by Service technicians and then deleted. The respective status text flashes on the LCD. These messages are also marked with an asterisk.

Furthermore, sensor reliability is constantly monitored by the control system. If the sensors respond, a fault message is sent via the remote monitoring system. Depending on the sensor, the turbine may continue to operate for a certain amount of time. If certain sensors respond, the turbine has to be stopped immediately and the fault rectified.

2.2 Starting the turbine

Unless expressly stated otherwise, these instructions apply to startup after an automatic shutdown and for operation start up with the start/stop switch.

When the turbine is switched on (main switch on control cabinet to "ON" and start/stop switch is set to start), "Turbine operational" appears on the LCD shortly afterwards (status 0:2), provided the E-82 control system has not detected any faults. Ninety seconds after start-up, the rotor blades are driven out of the feathered position (approx. 90°) and "idle mode" begins. The rotor starts turning slowly. The turbine begins the actual operations startup procedure when the average wind speed is greater than the required startup wind speed for three consecutive minutes.

2.3 Normal operation

Once the E-82 startup procedure is completed, the wind energy converter switches to normal operation. During operation, the wind conditions are continuously determined: rotor speed, generator excitation and output are optimised, the nacelle position is adjusted to the wind direction and all sensor messages are recorded. When outside temperatures are high and if the wind speeds are also elevated, the generator fan is switched on.

2.3.1 Operation at partial load

During operation at partial load, the speed and power output are continuously adjusted to the changing wind conditions. In the upper partial load range, the rotor blades are pitched a few degrees to avoid flow interruption (stall effect).

As wind speed increases, the rotor speed and power output increase.

Document information:	Translation Information
Author/date: S. Anlas / 21.10.05	Translated/date: C.Carsted / 28.11.05
Department: VI	Revised/date:
Approved/date: M.Kuhlmann / 04.11.05	Reference: VI-Technical Description E-82-Rev002ger-eng
Revision 2/10.02.06	

2.3.2 Automatic control mode

When the wind speed exceeds the rated wind speed, the blade angle is adjusted to maintain the rotor speed at / or around its rated value and to limit the use of the wind's power ("automatic control mode"). The required blade angle adjustment is determined by evaluating speed and acceleration measurement data which is then transmitted to the pitch drives. This maintains power output at its rated value.

2.4 Idle mode

If the turbine is shut down (e.g. due to lack of wind or faults), the rotor blades are normally positioned at a 60° angle in relation to the operating position. The turbine then rotates at a slow speed. If this speed (approx. 3 U/min) is exceeded the rotor blades are pitched further into the feathered position (approx. 90°). This operating mode is called "idling". Idling reduces load and enables the turbine to be restarted in the shortest possible time. The reason for turbine shutdown or idle mode is indicated by the status message.

2.5 Stopping the turbine

The E-82 can be stopped by manually activating the start/stop switch and the EMERGENCY STOP button. The control system stops the turbine in the event of faults or unsuitable wind conditions (see Figure 3).

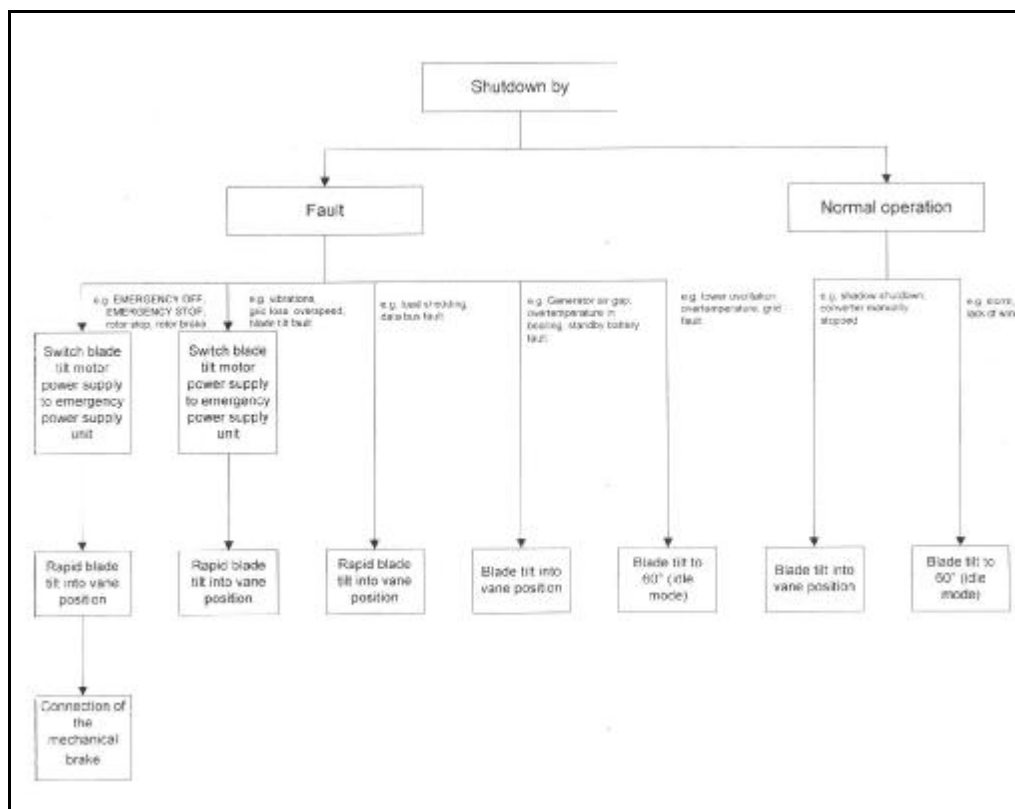

Figure 3: Shutdown procedures for the E-82

Document information:	Translation Information
Author/date: S. Anlas / 21.10.05	Translated/date: C.Carsted / 28.11.05
Department: VI	Revised/date:
Approved/date: M.Kuhlmann / 04.11.05	Reference: VI-Technical Description E-82-Rev002ger-eng
Revision: 2/10.02.06	

2.5.1 Automatic shutdown

In automatic mode, ENERCON wind energy converters are only brought to a standstill aerodynamically by pitching the rotor blades. Pitching the rotor blades reduces the aerodynamic lift force which slows the rotor down. The pitch control devices can drive the rotor blades out of the wind (i.e. into the feathered position) within seconds.

The turbine also stops automatically when certain faults or operating events occur or under certain wind conditions. Some faults cause rapid shutdown to occur. This happens via the rotor blades' backup power units. Other faults result in a normal shutdown.

Automatic restart may be possible depending on the type of fault. In each case the converters are electrically isolated from the grid during shutdown.

2.5.2 Manual stop

The E-82 can be stopped via the start/stop switch on the control cabinet. The control system then pitches the rotor blades out of the wind and the turbine slows to a halt. The brake is not activated and yaw control remains in operation so that the E-82 can continue to optimally adjust to the wind.

2.5.3 Manual shutdown in emergency situations

If individuals or turbine parts are at risk, the turbine can be stopped by pressing the EMERGENCY STOP button. An EMERGENCY STOP button is located on the control cabinet. Pressing it will induce immediate emergency braking on the rotor with rapid pitch control via the emergency pitch and brake units. At the same time the mechanical brakes are activated. All components continue to be supplied with power.

The buttons are latched and have to be pulled back to their original position once the emergency has passed and the turbine is to be restarted.

If the main switch on the control cabinet is set to the OFF position, all turbine components, except for tower and control cabinet lighting and individual light switches and sockets, are switched off. The turbine activates rapid pitch control via the emergency pitch devices. The mechanical brake is not activated when the main switch is used.

2.6 Lack of wind

If the turbine is in operation and the rotor speed drops too low due to lack of wind, the turbine is switched to idle mode by slowly pitching the rotor blades towards the 60° angle. The turbine then restarts automatically when the cut-in wind speed is reached.

If the anemometer freezes due to low temperatures (<3°C), the turbine attempts to start at hourly intervals to test whether the wind speed is sufficient for operation when the wind vane is functioning. If the turbine starts and produces power, it goes into normal operation. However, the correct wind speed does not appear on the display since the frozen sensor cannot provide accurate wind speed data.

Document information:	Translation Information
Author/date: S. Anlas / 21.10.05	Translated/date: C.Carsted / 28.11.05
Department: VI	Revised/date:
Approved/date: M.Kuhlmann / 04.11.05	Reference: VI-Technical Description E-82-Rev002ger-eng
Revision 2/10.02.06	

2.7 Storm

From the standstill position or idle mode the turbine does not start up at wind speeds over 25 m/s. If an average wind speed of 25 m/s or a top value of 30 m/s is exceeded, the E-82 automatic control mode stops. The turbine also stops if the maximum permissible blade angle is exceeded. A frozen anemometer therefore does not represent a safety risk. In all cases the turbine switches to idle mode.

The E-82 components, such as rotor blades, nacelle, tower and foundations are designed to withstand considerably higher wind speeds.

The turbine starts automatically if the wind speed drops below cut-out wind speed (25 m/s) for 10 consecutive minutes.

When wind speeds surpass 22 m/s the ENERCON Storm Control System does not shut down the turbine abruptly, but rather reduces the power by continuously pitching the rotor blades. The output is only reduced to zero at wind speeds of approx. 28 m/s. This strategy improves electrical behaviour in the grid at the same time increases output.

2.8 Yaw control

The E-82 has a combination wind sensor, which is installed on the top of the nacelle. The combined wind sensor comprises a wind vane, which constantly determines the wind direction, and an anemometer, which measures wind speed.

E-82 yaw control already starts to operate below the cut-in wind speed of 2 m/s. Even if the system shuts down (e.g. due to excessive wind speed), it adjusts according to the wind conditions. The angle and the period of measurement depend on the wind speed and turbine performance.

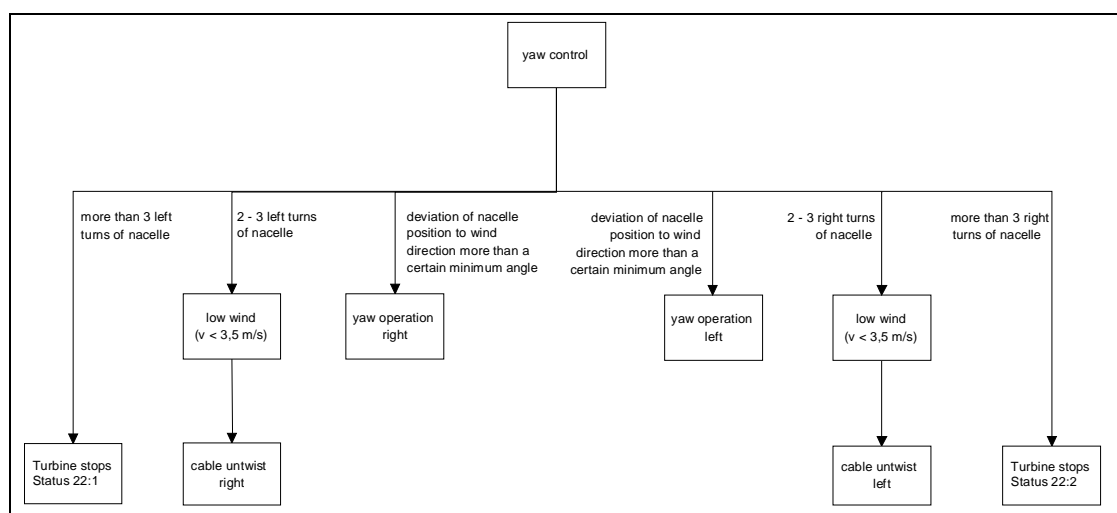

Figure 4: Illustration of yaw control

Document information:	Translation Information
Author/date: S. Anlas / 21.10.05	Translated/date: C.Carsted / 28.11.05
Department: VI	Revised/date:
Approved/date: M.Kuhlmann / 04.11.05	Reference: VI-Technical Description E-82-Rev002ger-eng
Revision: 2/10.02.06	

Yaw procedure is determined by counting the pitch motor rotations and the required pitch time is checked for plausibility. If the control system detects irregularities in yaw control or cable untwisting (See following), shutdown procedure is initiated.

2.8.1 Untwisting power and control cables

The E-82 power and control cables located in the tower pass from the nacelle over a deflection pad and are then fastened to the tower wall. The cables have enough freedom of movement to permit the nacelle to rotate several times in the same direction about its axis. The cables gradually twist. The E-82 control system ensures that the twisted cables are automatically unwound.

Once the cables have been twisted two and three times, the control system uses the next low-wind period to untwist the cables. If, however, high wind conditions continue and the cables have twisted more than 3 turns, the turbine stops and the cables untwist irrespective of wind speed. The cables take about half an hour to untwist. Once the cables have untwisted, the turbine automatically restarts.

The cable twist sensors can be found on the so-called cable twist switch, which in the E-82 is fitted near the access hatch. The sensor is connected via a gearwheel and gearbox to the yaw slewing ring. Changes in the nacelle direction are transmitted to the operation control system.

Furthermore, clockwise and anti-clockwise limit switches transmit whether the permissible limit has been exceeded in either direction (cable twist limit switch clockwise or anti-clockwise). This prevents the tower cables from twisting further. The turbine stops and cannot be restarted automatically.

Document information:	Translation Information
Author/date: S. Anlas / 21.10.05	Translated/date: C.Carsted / 28.11.05
Department: VI	Revised/date:
Approved/date: M.Kuhlmann / 04.11.05	Reference: VI-Technical Description E-82-Rev002ger-eng
Revision 2/10.02.06	

3 TECHNICAL SPECIFICATIONS:

Turbine type:	ENERCON E-82
Rated power:	2000 kW
Rotor diameter:	82 m
Hub height:	78 – 108 m (tower and foundation options)
 Turbine concept:	 Gearless, variable speed, single blade pitch control
 Rotor	
Type:	Upwind rotor with active pitch control
Rotational Direction:	Clockwise
No. of blades:	3
Swept area:	5281 m ²
Blade material:	Fibreglass (epoxy resin); integrated lightning protection
Speed:	Variable, 6 – 19,5 rpm
Tip speed:	25 - 80 m/s
Pitch control:	ENERCON blade pitch system, one independent pitching system per rotor blade with allocated emergency supply
 Drive train with generator	
Hub:	Rigid
Main bearing:	Dual row tapered / cylindrical roller bearings
Generator:	ENERCON direct-drive synchronous annular generator
 Grid power feed:	 ENERCON inverter

Document information:		Translation Information	
Author/date:	S. Anlas / 21.10.05	Translated/date:	C.Carsted / 28.11.05
Department:	VI	Revised/date:	
Approved/date:	M.Kuhlmann / 04.11.05	Reference:	VI-Technical Description E-82-Rev002ger-eng
Revision	2/10.02.06		

Braking system	- 3 independent pitch systems with emergency power supply - Rotor brake - Rotor lock
Yaw control:	Active via adjustment gear, load-dependent damping
Cut-in wind speed:	2.5 m/s
Rated wind speed:	12 m/s
Cut-out wind speed:	22 - 28 m/s
Remote monitoring:	ENERCON SCADA

Document information:		Translation Information	
Author/date:	S. Anlas / 21.10.05	Translated/date:	C.Carsted / 28.11.05
Department:	VI	Revised/date:	
Approved/date:	M.Kuhlmann / 04.11.05	Reference:	VI-Technical Description E-82-Rev002ger-eng
Revision	2/10.02.06		